

Machines à emballer sous vide

Vacuum machines

Gamme complémentaire
Complementary range

Les machines à emballer sous vide
Dapack vous garantiront une souplesse
et une sécurité de travail.

VACUUM MACHINE *The Dapack vacuum
packing machine will warrant to you a flexibility
and a safety work.*



"D300"

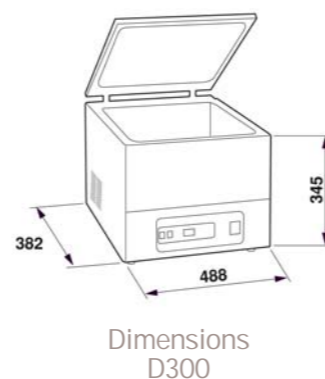

Dimensions
D300

Entièrement INOX

Cuve inox
avec angles arrondis

Adapté pour la conservation de la
viande, la charcuterie, le fromage,
le poisson, les pâtes....

Le système électronique contrôle le
taux de vide et le temps de soudure.

Volume de la cloche ajustable avec
plaque de polyéthylène

Très facile à nettoyer.

Remise en atmosphère lente pour
D500/40; 500/60; D550S de série

Conforme aux normes C.E.

Entirely stainless steel

Stainless steel bowl
with rounded corners

Adapted for the preservation
of meat, delicatessen, cheese,
fish, pasta....

Electronic system controls the vacuum
rate and the welding time.

Adjustable hopper volume with poly-
éthylène plate

Very easy to clean

Put in slow atmosphere for D500/40;
D500/60; D550S

Complies with CE norms

Options disponibles - Available Options :

Table pour D300 et D400

- Table for D300 and D400

Injection de gaz - Gas injection

Remise en atmosphère lente D400 D500

- Put in slow atmosphere (only for D400 D500)

Emballage export - Export packaging :

Caisse bois - Woodenbox



"D400 + socle"



Dimensions
D400



Panneau de commande D400
Control board of D400

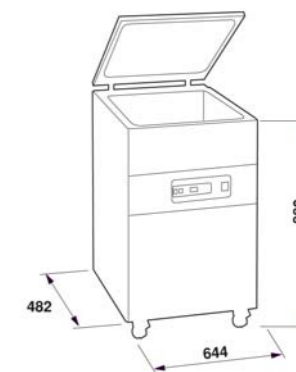

Dimensions
D450

"D450"



"D500/40"

"D500/60"

Dimensions
D500/40 - D500/60



Panneau de commande
D500-60 avec option soft air
Control board with soft air option

Dimensions
D550S

"D550S"

Réf Ref	Tension Tension	Barre de soudure Welding bar	Pompe à vide Vacuum pump	Dimensions cloche mm Hoper dimensions mm	Poids Weight
D300	MONO, 230 V	300 mm	20 m ³ / h	322 x 365 x 160	47 Kg
D400	MONO, 230 V	400 mm	20 m ³ / h	422 x 503 x 220	67 Kg
D450	TRI, 400 V	400 mm	40 m ³ / h	422 x 503 x 220	95 Kg
D500/40	TRI, 400 V	500 mm	40 m ³ / h	506 x 488 x 220	111 Kg
D500/60	TRI, 400 V	500 mm	60 m ³ / h	506 x 488 x 220	111 Kg
D550S	TRI, 400 V	2 x 550 mm	60 m ³ / h	720 x 558 x 265	160 Kg